

Teaching Reform of Course Group Regarding Theory and Design of Mechanisms Based on MATLAB Technology

Yi Shen^{1,2}, Mingxin Yuan^{1,2} & Mingqiang Wang^{1,2}

¹ School of Mechatronics and Automotive Engineering, Jiangsu University of Science and Technology, Zhangjiagang, China

² Suzhou Institute of Technology, Jiangsu University of Science and Technology, Zhangjiagang, China

Correspondence: Yi Shen, School of Mechatronics and Automotive Engineering, Jiangsu University of Science and Technology, Zhangjiagang 215600, China. Tel: 86-512-5673-1512. E-mail: sheny456@hotmail.com

Received: July 30, 2013 Accepted: September 24, 2013 Online Published: November 22, 2013

doi:10.5539/hes.v3n6p15

URL: <http://dx.doi.org/10.5539/hes.v3n6p15>

Abstract

Considering that the course group regarding theory and design of mechanisms is characterized by strong engineering application background and the students generally feel very boring and tedious during the learning process, some teaching reforms for the theory and design of mechanisms are carried out to improve the teaching effectiveness in this paper. Taking the engineering cases as the teaching objectives, we combine the course contents with the engineering background. Moreover, in order to help the students understand the knowledge difficulty and improve the design capacity of the mechanisms and machines, the matlab technology is introduced into the theoretical teaching to provide assisted analysis. At the same time, the matlab is also introduced into the practical teaching to provide theoretical guidance. The teaching effect shows that matlab—based teaching reform under the engineering application can deepen the understandings of course contents for students, improve the interest in learning, strengthen the design capacity and develop the innovation ability.

Keywords: theory of mechanisms, design of mechanisms, engineering background, teaching reform, Matlab

1. Introduction

Theory and design of mechanisms are very important specialized core courses to mechanical engineering students, and serve as a connecting link between the preceding and the following in the whole curriculum system. The course regarding theory of mechanisms is to introduce the basic concepts, basic theories and basic methods for the design and analysis of mechanisms; the course regarding design of mechanisms is to introduce the design principles and design methods of general machinery parts, and the general laws of mechanical design. Through the study of the mentioned course group, the comprehensive analysis capacity, design capacity, innovation capability and practical problem-solving capacity for students are cultivated. The course group regarding theory and design of mechanisms is characterized by deep theory and many knowledge points. A majority of knowledge points are from engineering practice; however, the students often lack engineering experience and have no perceptual knowledge to the mechanical structure and parts. During the learning process, they often feel that the course contents are very abstract and boring, so their learning initiative has been greatly reduced. In recent years, with the further optimization of the personnel training programs and the reform of the course system, the contents of the course group are constantly updated and added; however, the total class hours of the course group are constantly being reduced. How to resolve the conflict between the fewer class hours and more teaching contents, and help the students to obtain more class information and acquire more course knowledge with less class hours has been paid great attention by the Chinese front-line teachers (Wang, 2002; Tian & Han, 2013; Sun *et al.*, 2010). The reforms of teaching methods with respect to the mentioned course group must be enforced. The traditional teaching methods should be combined with the modern teaching methods, and some modern computer technologies should be applied to the class teaching to help the students master the knowledge points.

2. Literature Review

In view of the characteristics of the course group regarding the theory and design of mechanisms, some teaching reforms are carried out by the Chinese front-line teachers. Throughout the last decades, the teaching reforms for the course group in China have yielded a rich harvest. Based on the close cooperation between the experiment

center of mechanical engineering and the department of the mechanical engineering in the Jiangsu University, Ma Chaoxing and Ma Luzhong (2002) carried out the teaching reforms on the theory and design of mechanisms. In order to improve the teaching effectiveness, he hoped that the teaching should be finished according to the different majors and different levels of knowledge. Moreover, some modern design methods, such as Pro/E, Ansys and Matlab, should be introduced into the course teaching. Based on the practical teaching experience on the curriculum design of theory and design of mechanisms, Zhu Yu (2007) carried out a series of explorations and practice concerning the problems in practical teaching. For example, he advocated that the thought of PRP (Product Realization Process) should be introduced into the teaching, and some modern design techniques, such as Pro/E, UG, SolidWorks and ADAMS, should be used in the curriculum design. From the teaching results, we can see that the PRP-based teaching is valid, and the innovative design capability of the students is improved obviously. Considering that the practical teaching of theory and design of mechanisms is one of non-negligible aspects in the whole teaching system of mechanical engineering in universities, and plays an important role in cultivating undergraduates, aiming at the disadvantages of the traditional experimental teaching such as the isolation and incompleteness of experimental projects, Qiu Wenlong (2004) carried out some experimental teaching reforms. He built an experimental platform for the cultivation of innovative ability, absorbed the new scientific and technological achievements into the course experiments and made full use of the modern experimental teaching method (namely computer-aided test and analysis) to improve the quality of experimental teaching.

A series of teaching reforms help to deepen the understanding of class knowledge, and improve the teaching effects; however, the abilities regarding playing the students' learning initiative and mechanical design are not improved well. The reason is due to the courses of theory and design of mechanisms own strong engineering application background, and the students can't combine the theoretical knowledge with actual mechanical system for lacking engineering experience. It is difficult to improve the learning initiative, and the mechanical design ability can not be cultivated well.

In order to further improve the teaching effects of theory and design of mechanisms, the teaching reforms based on engineering cases are carried out. At the same time, the matlab language is introduced into the daily teaching. The advantages of simple programming and quick visualization of graphics are used to help students to analyze the mechanism motions, and the strong computing ability is used to help students combine theoretical design with engineering practice.

3. Teaching Reform for Theory of Mechanisms

The research contents of theory of mechanisms include: Structure, force, mass and movement of machine components. The teaching contents are relatively abstract and boring, and the learning initiative of students is not high. In order to change this situation, recently, engineering cases are introduced in the teaching of theory of mechanisms by our group members. For example, during the teaching of crank-rocker mechanism, the pitching mechanism of radar antenna is introduced. During the teaching of slider-crank mechanism, the engine is introduced. Table 1 gives the partial engineering cases for the mechanism teaching.

Table 1. Engineering cases for the mechanism teaching

No.	Name of mechanism	Engineering case
1	Crank-rocker mechanism	①Pitching mechanism of radar antenna; ②Foot pedal mechanism of sewing machine; ③Pumping jack mechanism; ④Ballast crusher.
2	Double-crank mechanism	①unbalanced throw screen; ②Locomotive wheels linkage; ③Seeder; ④Lift truck.
3	Double-Rocker Mechanism	①Car front wheel steering mechanism; ②Aircraft landing gear mechanism; ③Crane.
4	Slider-crank mechanism	①Engine; ②Umbrella; ③Closing mechanism of car door.
5	Guide rod mechanism	①Shaper; ②Dumper lorry.
6	Fixed-Slider Mechanism	①Hand pumps; ②Feeding mechanism of oven door.

Engineering cases—based teaching helps students understand the application of knowledge points in engineering and improves the learning initiative of the students; however, it is difficult to help students understand the working principle of knowledge points in essence. In theory of mechanisms, the motion analysis and dynamic analysis of mechanisms are the key parts of the course. During the teaching of these knowledge points, the graphic method and analytic method are usually adopted. The former is visual and intuitionistic. The vector equation is needed to be listed firstly, then the results are achieved through drawing; however, their accuracy is poor. The latter needs students to construct mechanical model, then the accurate results can be achieved through programming; however, the teaching effect is limited by the programming skills of the students. To stimulate the learning initiative and improve the understanding of knowledge points, our research group introduced the matlab software into the courses to improve the teaching effects of theoretical and practical teaching.

3.1 Theoretical Teaching Reform Based on Matlab

Matlab is developed by American Mathworks Corporation, which is characterized by simple programming, strong function and rapid graphic displaying. In order to complete the motion analysis and dynamic analysis of mechanisms quickly and accurately, help students deepen their understanding of course contents, and improve the abilities of analyzing and solving the problems, the matlab software is introduced to analyze the theoretical knowledge points during the course teaching. According to the book—*MATLAB—based assisted analysis for theory of mechanisms* (Li & Xu, 2011), which is written by the teachers in our school, aiming at the planar linkage mechanism, cam mechanism, gear mechanism, etc., we use the matlab software to help students understand the movement analysis and force analysis of some mechanisms on the basis of mathematical modeling. In order to further describe the teaching methods, we take the slider-crank mechanism as an example, and give a teaching case regarding the assisted analysis of movement and fore based on Matlab.

3.1.1 Assisted Analysis of Movement for Slider-Crank Mechanism

Figure 1 gives a slider-crank mechanism. In the figure, AB is the drive link, and is in a counterclockwise rotation with the constant angular velocity of 5 rad/s. The lengths of crank 1 and connecting rod 2 are 200mm and 600mm respectively, namely $l_1=200mm$ and $l_2=600mm$. With the rotation of crank 1, the changing angle between the crank1 and horizontal axis Ax is α_1 , the changing angle between the connecting rod 2 and Ax is α_2 , the angular velocity of connecting rod 2 is ω_2 and the angular acceleration is a_2 . Let the velocity and acceleration of slider 3 is V_C and a_C respectively. In order to clearly show the movement information of crank and slider (Xu, et al.,2004), our research group firstly finishes the mathematical modeling of slider-crank mechanism based on the analytic method.

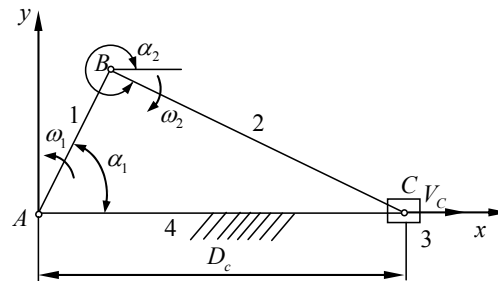

Figure 1. Slider-crank mechanism for movement analysis

(1) Displacement model of slider and crank

$$\alpha_2 = \arcsin\left(\frac{-l_1 \sin \alpha_1}{l_2}\right) \quad (1)$$

$$D_C = l_1 \cos \alpha_1 + l_2 \cos \alpha_2 \quad (2)$$

(2) Velocity model of slider and crank

$$\begin{bmatrix} l_2 \sin \alpha_2 & 1 \\ -l_2 \cos \alpha_2 & 0 \end{bmatrix} \begin{bmatrix} \omega_2 \\ V_C \end{bmatrix} = \omega_1 \begin{bmatrix} -l_1 \sin \alpha_1 \\ l_1 \cos \alpha_1 \end{bmatrix} \quad (3)$$

(3) Acceleration model of slider and crank

$$\begin{bmatrix} l_2 \sin \alpha_2 & 1 \\ -l_2 \cos \alpha_2 & 0 \end{bmatrix} \begin{bmatrix} a_2 \\ a_c \end{bmatrix} + \begin{bmatrix} \omega_2 l_2 \cos \alpha_2 & 0 \\ \omega_2 l_2 \sin \alpha_2 & 0 \end{bmatrix} \begin{bmatrix} \omega_2 \\ V_c \end{bmatrix} = \omega_1 \begin{bmatrix} -\omega_1 l_1 \cos \alpha_1 \\ -\omega_1 l_1 \sin \alpha_1 \end{bmatrix} \tag{4}$$

After achieving the models of position, velocity and acceleration, the Matlab software with strong calculation and drawing capabilities is used to draw the moving information of slider-crank mechanism. The drawing results are shown in Figure 2. From the figures, the students can clearly see the changes (namely displacement, velocity and acceleration) of connecting rod 2 and slider 3 with the change of rotation angle of crank 1, which helps the students understand the movement of slider-crank mechanism.

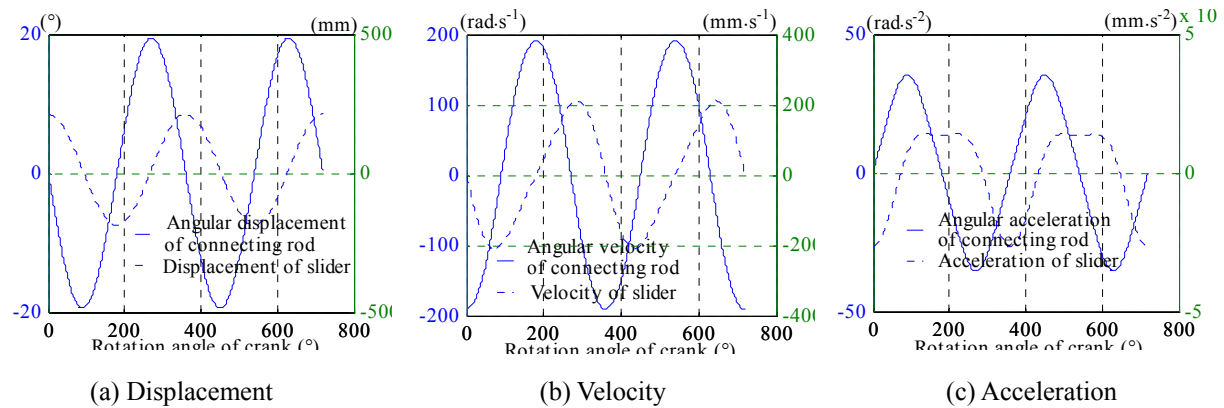

Figure 2. Moving information of slider-crank mechanism

3.1.2 Assisted Analysis of Force for Slider-Crank Mechanism

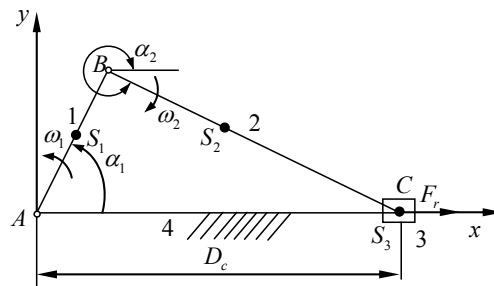

Figure 3. Slider-crank mechanism for force analysis

The analysis of force for slider-crank mechanism can also be realized based on the Matlab software. On the basis of Figure 1, three centers of mass (namely \$S_1\$, \$S_2\$ and \$S_3\$) are added in crank 1, connecting rod 2 and slider 3 as shown in Figure 3. \$l_{AS_1} = 100mm\$, \$l_{BS_2} = 300mm\$. An external force (\$F_r\$) is added on the slider 3, and \$F_r = -400N\$. In addition, let the mass of crank 1 (\$m_1\$) be \$0.5kg\$, mass of connecting rod 2 (\$m_2\$) be \$2kg\$, mass of slider 3 (\$m_3\$) be \$3kg\$ and the moment of inertia of connecting rod 2 (\$J_{S_2}\$) be \$0.25kgm^2\$.

In order to clearly explain the force of slider-crank mechanism to the students, our research group firstly has a force analysis on the components of slider-crank mechanism, and the results are shown in Figure 4.

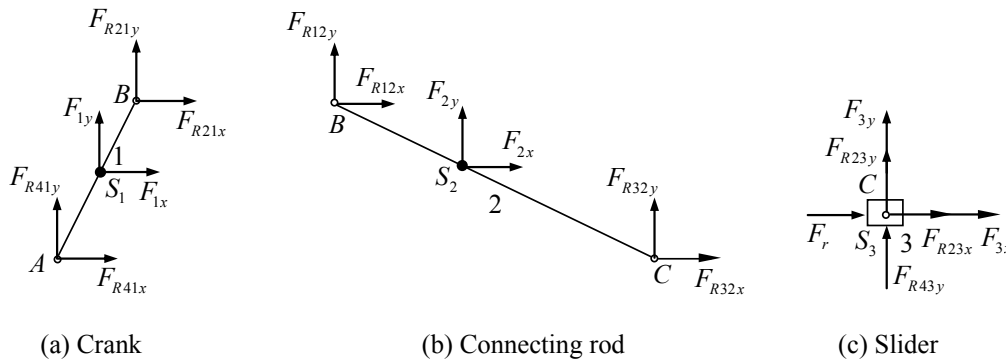

Figure 4. Force analysis of each component

After analyzing the force of each component, and then the inertial force, inertia moment and balance equation of each component can be built. Finally, the force of each component can be calculated based on the Matlab software and the forces are drawn in Figure 4.

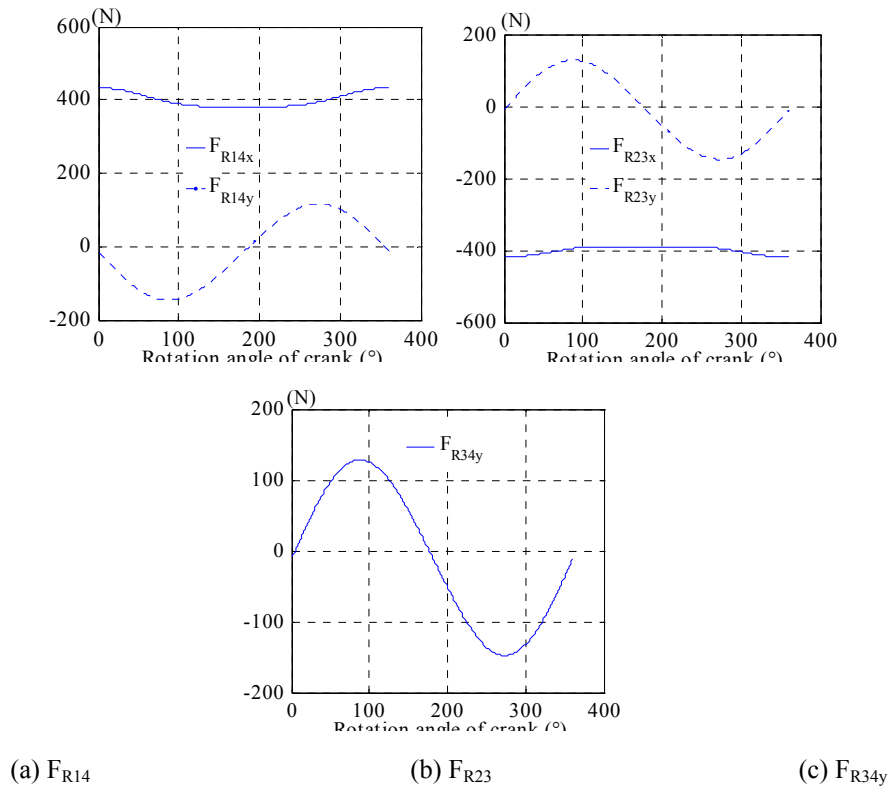

Figure 5. Force of Slider-crank mechanism

3.2 Experimental Teaching Reform Based on Matlab

The experiments of theory of mechanisms are extremely important practice on the basis of theoretical study. The experiments can deepen the understanding of basic concepts in the theory of mechanisms, and improve the abilities of analyzing and solving problems. Now, the experiments which are set up in design of mechanism include: surveying and mapping of moving sketch of mechanisms, dynamic balance test of rotor, mechanical transmission performance tests, and moving parameters tests, and so on. However, most of them are verification experiments and are not useful for students to cultivate the practical abilities. In order to better change the practice from the verification to design, and improve the comprehensive practice abilities of students, some experimental teaching reforms are carried out. In practical teaching, on the basis of engineering cases, we firstly

require students to finish theoretical computation and simulation using the matlab software, and then require them to finish the design of engineering cases based on experimental equipments.

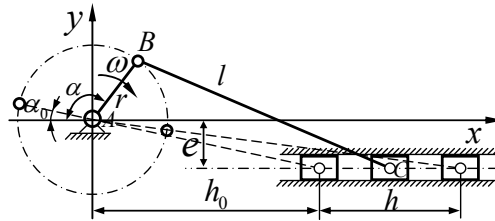

Figure 6. Sketch of the hacksawing machine

To further describe the teaching methods, we take the knowledge point of offset slider-crank mechanism as an example, and introduce the hacksawing machine. The moving sketch of the hacksawing machine is shown in Fig. 6.

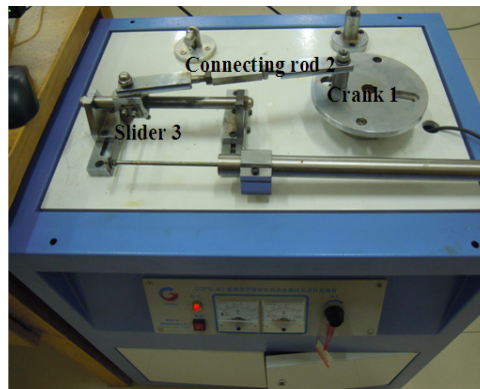

Figure 7. Experimental equipment of slider-crank mechanism

In the comprehensive experiment, the rotation angle of crank $\alpha = \alpha_0 \sim (\alpha_0 + 180^\circ)$, and the slider moves according to the following equation:

$$H(\alpha) = H_0 \times \frac{2}{\pi} \sin^2(\alpha - \alpha_0) \quad (5)$$

Where, α_0 and H_0 are the initial positions of crank and slider when the crank locates at the far left.

The purpose of this comprehensive experiment is to ask students to design the optimal structure parameters (namely r , l and e) and realize the model of the hacksawing machine on the experimental equipment of slider-crank mechanism (See Figure 7).

The whole comprehensive experiment includes the following four steps:

Step 1: $\mathbf{x} = [r, l, e]^T$ is selected by the students as design variables according to the experiment requirements, the range of the rotation angle of the crank is divided into 100 equal parts, and the objective function for optimization is built as follows:

$$\min f(\mathbf{x}) = \min \left(\frac{1}{100} \sum_{i=1}^{100} \left(h_0 \times \frac{2}{\pi} \sin^2(\alpha - \alpha_0) - r \cos(\pi - \alpha) - \right. \right. \\ \left. \left. (l^2 - (r \sin(\pi - \alpha) + e)^2 + h_0^2)^{1/2} \right) \right) \quad (6)$$

The constraints include:

$$r + e - l \leq 0 \quad (7)$$

$$\sqrt{(l-r)^2 - e^2} - h_0 = 0 \quad (8)$$

$$300 - \sqrt{(r+l)^2 - e^2} - \sqrt{(l-r)^2 - e^2} = 0 \quad (9)$$

Step 2: The students achieve the range of design variables (namely $r \in [0.45m, 0.58m]$, $l \in [0.28m, 0.34m]$ and $e \in [0, 0.15m]$) through the measuring on the experimental equipment in Figure 7.

Step 3: Take the Eq.(6) as the fitness function, and achieve the optimal design variables (namely $r=0.567m$, $l=0.28m$, $e=0.055m$) through an optimization algorithm.

Step 4: Have a simulation design through the adjustments of all components in Figure 7 according to the optimization results, and then finish the movement test of the slider. The testing result is shown in Figure 8.

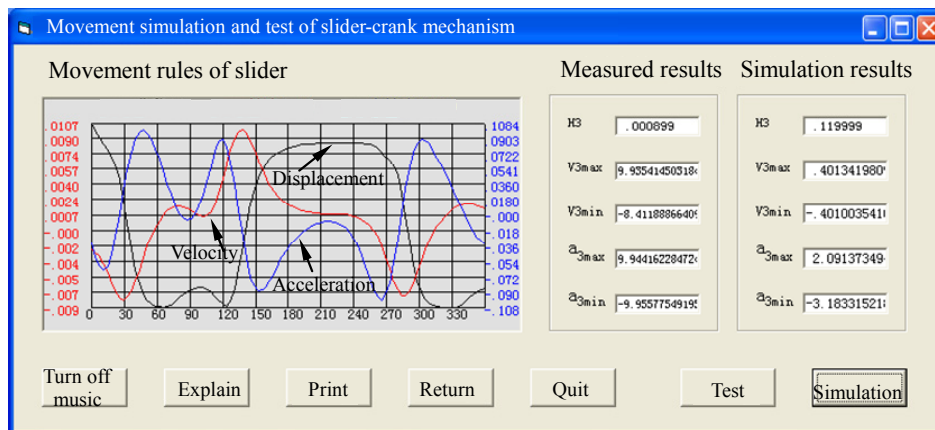

Figure 8. Testing result of movement for slider

The comprehensive experiment is different from the past verification experiment, and asks the students to finish the optimization, design and experiment according to the actual project needs. The experiment relates to the mathematical modeling, optimization, artificial intelligence, machine, testing and other knowledge, and realizes the integration of related knowledge. Through the comprehensive experiment, the students not only strengthen the operational capability, but also improve the learning initiative.

4. Teaching Reform for Design of Mechanisms

Design of mechanisms is a main technical course for mechanical engineering students, and is the basis for the design of mechanical products. Curriculum design is the most important practice for design of mechanisms, which helps students deepen the understanding and improve the comprehensive application ability of knowledge points. Now, the deficiencies in curriculum design include: Design titles are old, design methods are stiff and design tools are single, which can not stimulate the design interest of students. To culture the students' innovation ability, we carry out some reforms for the curriculum design. During the curriculum design, aiming at the design title, we firstly require the students to finish the optimization of mechanical products by using matlab, and then require students to use the optimization results to guide the product design. Thus it is helpful for students to improve their programming and design abilities. Here, we also give a teaching case to illustrate the reform.

One of design title is reducer. During the design, gear drive is the key component. We firstly give the following design conditions of straight cylindrical gear drive: Gear ratio $u=4$, axle torque of small gear $T_1=100N \cdot M$, material of small and large gears are 40Cr and 45 steel respectively, tooth surface hardness of small gear is 250HB~280HB, $[\sigma_H]_1=680MPa$, $[\sigma_F]_1=288Mpa$, tooth surface hardness of large gear is 220HB~250HB, $[\sigma_H]_2=550MPa$, $[\sigma_F]_2=204Mpa$, and load factor $k=0.8$. Then we require students to build the optimization

model according to the minimization of reference cylinder volume of two meshing gears. Eq.(10) gives the objective function (Xi Pingyuan, 2005; Shen Yi, 2008).

$$f(\mathbf{x}) = \pi * (D_1^2 + D_2^2) * B / 4 = (1 + u^2) * (m * z_1)^3 * \varphi_d / 4 \quad (10)$$

Where, D_1 and D_2 are the diameters of small gear and large gear, m is the gear module, z_1 is the tooth number of small gear and φ_d is the tooth width coefficient.

From Eq.(10), we can see that the optimization variables are m , z_1 and φ_d .

The constraint conditions include:

$$\text{Modules limit:} \quad 2 \leq m \leq 10 \quad (11)$$

$$\text{Tooth number limit of pinion:} \quad 17 \leq z_1 \leq 40 \quad (12)$$

$$\text{Tooth width coefficient limit:} \quad 0.7 \leq \varphi_d \leq 1.2 \quad (13)$$

Contact strength limit of tooth surface:

$$\sigma_H = Z_H * Z_u * Z_E * \sqrt{\frac{2 * k * T_1}{(m * z_1)^3 * \varphi_d}} \leq [\sigma_H] \quad (14)$$

Where, Z_H is node engagement factor, Z_u is gear ratio coefficient and Z_E is material factor.

Bbending strength limit of tooth root:

$$\sigma_F = \frac{2 * k * T_1}{m^3 * z_1^2 * \varphi_d} * Y_F * Y_S \leq [\sigma_F] \quad (15)$$

Where, Y_F is the gear shape factor and Y_S is the tooth root stress concentration factor.

To achieve better optimization results, we require students to finish the optimization based on the genetic algorithm (Chipperfield, A., Fonseca, C., and Pohlheim, H., 2010), which is an intelligent optimization algorithm, and is characterized by parallel computing, distributed search and global optimization, and the optimization program is run on the platform of matlab. The final optimization results are: $m=2$, $z_1=19$ and $\varphi_d=0.85362$.

After getting the optimization parameters of two meshing gears, the students can finish the design of reducer. Figure 9 gives the design results. Through the practice reform, the students not only master the compositive application of knowledge points, but also learn how to finish the engineering optimization, which helps students cultivate the innovation ability.

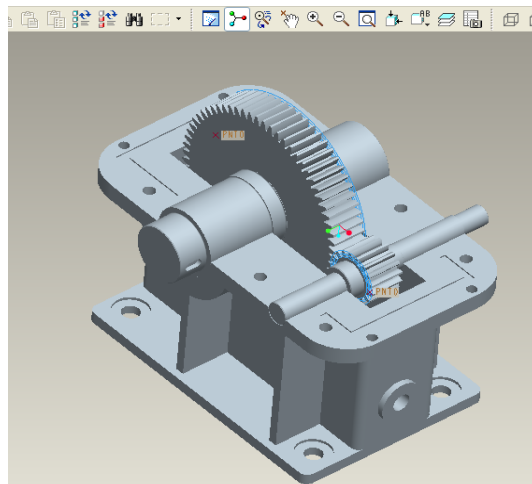

Figure 9. Design result of reducer in Pro/E

5. Conclusion

To improve the teaching effect of theory and design of mechanisms, on the basis of engineering cases, we carried out some teaching reforms through introducing matlab. Aiming at the theory of mechanisms, we use matlab to help students understand knowledge points in theoretical teaching, and use matlab to guide practice in experiments. Aiming at the curriculum design of design of mechanisms, we require students to design all products based on the theoretical optimization using matlab. The teaching reforms show that matlab-based engineering teaching reform helps students deepen the understanding of knowledge points, improve the interest in learning and cultivate the innovation ability.

It has been three years since the teaching reforms on the course group regarding theory and design of mechanisms were carried out. During the teaching reforms, our research group helps the students succeed in applying near 10 mechanical innovation projects. Two of the projects are the practice innovation training program projects for the Jiangsu College students. Two works, namely “Four axis aircraft” and “Service robot in smart room”, participated in the Mechanical Creative Design Match for College Students in Jiangsu in 2010 and 2012, respectively, and both won second prize. Another three mechanical works, namely “Throwing snow and garbage removal double-service truck for community”, “Intelligent classification dustbin for community” and “Intelligent shooting machine”, participated in the National College Mechanical Design and Innovation Competition (Fishertechnik Robot) in 2012, and all won third prize. The achievements of students verify the validity of proposed teaching reforms.

Acknowledgements

This work is supported by the Modern Educational Technology Project of Jiangsu Province (No. 2013-R-24771), Teaching Reform and Teaching Study Project from Jiangsu University of Science and Technology (JUST) and the Key Teaching Reform and Teaching Study Project from Zhangjiagang campus areas of JUST (No. GXS201304).

Reference

- Chipperfield, A., Fonseca, C., & Pohlheim, H. (2010). Genetic algorithm toolbox. Retrieved from <http://www.shef.ac.uk/cgi-bin/cgiwrap/gaipp/gatbx-download>
- He, W. D., Wang, C., Zhang, L., & Lai, L. L. (2011). Design methods of slider-crank mechanism based on matlab. *Journal of Lanzhou Polytechnic College*, 18(4), 55-57. <http://dx.doi.org/10.3969/j.issn.1009-2269.2011.04.015>
- Li, B. C., & Xu, C. (2011). *Assisted analysis based on MATLAB for theory of mechanism*. Beijing: Chemical Industry Press. <http://dx.doi.org/10.1016/j.mechmachtheory.2011.06.004>
- Ma, C. X., & Ma, L. Z. (2002). On the course reform of “theory and design” of mechanism. *Journal of Jingsu University (Higher Education Study Edition)*, 24(2), 91-93. <http://dx.doi.org/10.3969/j.issn.1673-8381.2002.02.023>
- Qiu, W. L. (2004). Reformation of experimental teaching of theory of machines and mechanisms and machine design. *Research and Exploration in Laboratory*, 23(12), 78-80. <http://dx.doi.org/10.3969/j.issn.1006-7167.2004.12.030>
- Shen Y. (2008). The GA optimal Design of straight bevel gear based on RBF network. *Journal of Huaiyin Institute of Technology*, 17(1), 24-27.
- Sun, L. B., Kong, J. Y., Huang, M. F., & Gui, H. (2010). Research on and practice of the machine innovate design project in mechanisms and machine theory teaching. *Journal of Machine*, 37(12), 21-24. <http://dx.doi.org/10.3969/j.issn.1006-0316.2010.12.006>
- Tian, J., & Han, L. F. (2013). Mechanical design basis teaching reform under excellent engineers training objectives. *Journal of Dongguan University of Technology*, 20(1), 100-104.
- Wang, C. H. (2002). The teaching reform about the course of mechanism principle. *Journal of Liaoning Technical University (Social Science)*, 4(3), 135-136. <http://dx.doi.org/10.3969/j.issn.1008-391X.2002.03.064>
- Xi, P. Y. (2005). Genetic Algorithm Optimization of Gearsets Applying Neural Networks. *Journal of Mechanical Transmission*, 29(5), 61-63. <http://dx.doi.org/10.3969/j.issn.1004-2539.2005.05.020>
- XU, Z. B., Min, J. Q., Huang, X. Y., & Shen, G. Z. (2004). The dynamic analysis of the crank-connecting rod of single-cylinder internal combustion engine base on MATLAB. *Machine*, 31(5), 48-50.

<http://dx.doi.org/10.3969/j.issn.1006-0316.2004.05.016>

Zhu, Y. (2007). On teaching exploration and practice about the course design of principle and design of machines. *Journal of Nanjing Institute of Technology (Social Science Edition)*, 7(1), 52-55.
<http://dx.doi.org/10.3969/j.issn.1671-3753.2007.01.013>

Copyrights

Copyright for this article is retained by the author(s), with first publication rights granted to the journal.

This is an open-access article distributed under the terms and conditions of the Creative Commons Attribution license (<http://creativecommons.org/licenses/by/3.0/>).